

I think therefore i-Phone

Abstract

This paper is concerned with the ongoing usage of mobile computing and cellular phones for collaboration. In particular it focuses on the interdisciplinary thresholds found within design and construction. Through participation in a building project we analyze the subtleties of interaction between analogue communications, such as sketches and digitally sponsored communication, such as e-mail and mobile phones. An analysis of the communications between the designer and builder during construction suggests the distinctions between design and construction processes are complex and often blurred. This work provides an observational basis for understanding mobile computing as a dynamic ‘tuning’ device—as hypothesized by Richard Coyne [1]—that ameliorates the brittleness of communication between different disciplines. Within multidisciplinary collaboration individual communiqués have different levels of importance depending on the specific topic of discussion and the time and place of the contributing participant. This project expands upon what mobile computing is and enables us to infer how these emergent devices affect collaboration. Findings suggest the synchronous and asynchronous clamor of analogue and digital communications that surround design and construction are not exclusively inefficiencies or disruptions to be expunged. Observational evidence suggests they may provide contingency and continue to have value attending to the relationships within complex systems such as design and construction. Finally we briefly discuss a current follow up investigation, ‘digital fieldnotes’ (dfn) is a bespoke iPhone/iPad application designed to test further suppositions regarding the influence mobile computing exerts upon group working.

Codifying design and construction

The *Ten Books on Architecture* by Vitruvius is possibly the most enduring example of the codification of design and construction. Written in approximately 27 BC [2] it remained the seminal and authoritative architectural text until the eighteenth century [3]. The influence of this manuscript can still be felt in contemporary construction. For example, emergent tools from the Design Quality Indicator are based on principles found in *The Ten Books on Architecture* [4]. The desire to codify and order—according to the anthropologist Mary Douglas—is a basic human instinct [5]. This is perhaps best summarized in Vitruvius' basic accounts of construction as bringing order to the natural environment through the placing of the primary gnomon.

Vitruvius' codification is primarily concerned with rules for architectural success. By outlining the relationships that should exist between architectonic constituents to produce pleasing and successful architecture. However, more prevalent in contemporary construction are rules and frameworks such as the RIBA Plan of Work, where organizational mechanisms have expanded and now include sequencing and, to some extent, the interactions of participants.

Frameworks like the RIBA Plan of Work portray design and construction as a linear process. This perhaps evokes Shannon and Weaver's seminal thesis on communication [6], which suggests communication operates through a linear metaphor where a message is broken down, transmitted through a medium and reassembled accurately at another location. However, Michael Reddy [7] has challenged this conception of communication, suggesting where the message is crossing a cultural frame of reference the metaphor breaks down. Reddy claims that even though a message might be transmitted accurately, the intention can be misunderstood within a different cultural paradigm. He proposes the Toolmakers Paradigm, which is a repetitive communicative exchange that promotes iterative convergence on a common meaning. Reddy argues this is a more accurate and successful model for inter-cultural communication. This supposition by Reddy resonates with observed behavior during design and construction. Mark Burry has commented on the complexity of trans-disciplinary communication elsewhere [8] and in *How Designers Think* Brian Lawson writes:

“Certainly it is reasonable to argue that for design to take place a number of things must happen. Usually there must be a brief assembled, the designer must study and understand the requirements, produce one or more solutions, test them against some explicit or implicit criteria, and

communicate the design to clients and constructors. The idea, however, that these activities occur in that order, or even that they are identifiable separate events seems very questionable.” [9]

Lawson and Burry sensitize us to the arcane and nuanced communication that exists during design and construction, but do not romanticize these creative processes with exhortations that they are incompatible with codification. We would suggest where multiple agents are involved from differing cultural value frameworks that a linear codification does not retain the nuances and detail of translation and communication that seems to resurface in both Burry’s and Lawson’s work. The detailed translations and negotiations that are embedded in the nuances of design and construction processes are fluid and problematic to contain in a prescribed framework. It is around these esoteric communicative practices we find mobile phones and face-to-face meetings.

Communicative complexity

Within construction, mobile phones are particularly prolific [10] and a regular point of contention. They are now giving way to the increased proliferation of mobile computers and smart phones capable of increasingly sophisticated and diverse communication and computational processes. The appropriation of mobile tools such as Blackberry, iPhone or tablet computers alter the politics of conversation, collaboration and negotiation. Information can now be easily drawn into—and affect—situations, concurrently data can be pushed out of these situations enabling external agents to participate, monitor or contribute to a conversation or discussion. These communicative opportunities perhaps favor the ‘sociable expert’ [11], who is more ready to share and appropriate community knowledge. According to Sennett this results in the sociable expert being more able than the anti-social expert to embrace newness and thus stay current. We see a raft of communities and websites such as Sharable (<http://shareable.net/>) serving as catalysts for new movements, communities and businesses that often are sponsored by these emergent social communication tools. Coyne has recently invoked the metaphor of ‘tuning’ [1] to describe the use of pervasive media such as mobile phones and digital music players in social space. In both a mechanical and acoustic sense tuning consists of finding an optimal albeit imperfect relationship between various agents that exist in a state of tension; the strings of a piano or guitar being an obvious example of this. Tuning is also conditional on context, for example it is not uncommon practice to ‘retune’ carburetors to recalibrate the petrol/air intake ratio of a motorcycle

engine if intending to ride for prolonged periods at a considerably higher or lower altitude.

If we return for a moment to mobile phones and construction, Sennett claims sociable experts readily change, shift or tune a situation or their value framework by drawing on current context and people. This enables the sociable expert to seize opportunities in diagnosis, advance their expertise and stay current. Coyne posits that pervasive media is particularly adept at facilitating this contextual tuning by pulling information into, or pushing information out of, a particular situation. Mobile phones are implicated in the informal communication that sponsors casual sharing and exchange. Given the prolific uptake of mobile phones by design and construction participants, we suggest that mobile phones have value for innovation during construction, be that within problem solving or other creative processes.

To advance this hypothesis a practice-led research exercise was conducted, in which one of the authors—an architect—participated in and documented a domestic scale construction project. The project was to renovate a roof space in a small house in Scotland. The project was carried out to the canons of good practice following the RIBA Plan of Work. Communications were rigorously documented and particular attention was paid to the usage of mobile phones during the project.

Test cases in collaboration

For a period of seven months the author acted in the role of architect on the conversion of a roof space storage area into an additional bedroom for a family of five. Responsibilities for the role of architect began with the initial design development with the client and later involved submitting the design to the local authorities for approval. Finally, the project ended with the design and construction being approved by the local Building Control Authority and the client returning to live in the dwelling.

This project has been rigorously documented elsewhere [12], in this section we will limit our description to three key examples that will serve as vehicles for exploring the communication practices and the use of mobile phones within the construction process. They will be referred to as the fire escape, structural, and staircase examples; they are briefly outlined below. So that these examples can be understood for the purpose of the project they have been untangled from the overall process.

Fire Escape

This example revolves around a legal requirement to provide a means of fire escape in the newly converted roof space. Fire escape windows are highly prescribed; the Building Regulations specify size and critical dimensions for ease of escape by occupants and access by fire services. A highly specified drawing was issued to the building contractor with all critical dimensions and technical information necessary. However, the existing roof structure prevented the contractor achieving certain exact critical dimensions, he was required to make an impromptu value judgment concerning the position of the window. The contractor was dissatisfied with the fire escape window drawing because the window could not be installed as drawn. The window was installed in a position beyond several critical dimensions as specified within the building regulations. This proved problematic as the changes took place without the architect's knowledge and a delay was caused while the window position was negotiated with the local authorities.



Fig. 1 Fire escape window

Structural

In this example the building control division of the local authorities stipulated that the existing roof space floor structure would require

reinforcing to support the additional loading as a result of its change of use. An engineer was appointed who submitted a structural design for reinforcing the roof space floor to the local authority. This was quickly approved and allowed the structural changes to be implemented by the contractor on site. However, it transpired as the structural reinforcing work commenced that the engineering solution could not be achieved due to the unique way the existing roof space floor was constructed. It was necessary to stop construction work until the situation was resolved. After several phone calls between the engineer, architect and contractor it became apparent they would not arrive at a solution through remote communication alone and a site meeting was called.

When a structural solution was arrived upon, it had in fact been proposed earlier by the contractor and dismissed by the structural engineer. After the highly ritualized tendering and submission of the structural work this was a cause of some tension.

Staircase

Whereas the previous two examples are somewhat similar in that they deal with inconsistencies between the documentation and the site condition, this example proved different. The contractor and client made a joint decision—contrary to architectural advice—to remove the staircase sub-contract from the construction program, a direct saving of £1800. Instead the contractor would purchase a standard Screwfix staircase and—to quote the client—with some ‘jiggery-pokery’ modify it to fit. A Screwfix staircase was not recommended because of the restricted space available for the staircase and the intricate design necessary to conform to regulations. In the interest of a smooth running project it was advisable to sub-contract the staircase to a specialist.

It transpired that modifying the staircase proved too specialized for the contractor, who was unable to make any independent progress. After a consultation between the architect and the local authorities regarding its specifics, the contractor and architect met on site and together the key points, levels and dimensions of the stairs were marked on the walls and floor (**Fig. 2**). This process—when the relevant participants were present on site—was surprisingly quick, efficient and not at all confrontational.



Fig. 2 Staircase opening with the area marked by architect and contractor

Multidisciplinary communication: an analysis

In this section we recount our three test cases and analyze the communicative processes under the emergent themes of value frameworks and negotiation.

Tuning: a perspective on tensions within different value frameworks

All three of our test cases required more than one discipline to advance each particular situation, and mobile devices were implicated in the negotiations across different value frameworks. This was especially true in the fire escape example, which began with a confrontation between the architect and contractor. While such conflicts are not uncommon this particular disagreement occurred in the presence of the client, who was so distressed he felt compelled to leave. This problem was eventually addressed through a negotiation with the building control officer, builder and architect on-site. Resulting in the participants converging on a different window location, but one that would be acceptable to all parties. We could couch our observations within conceptions of boundary crossing. Historically we see examples of opportunity being found where places and people converge. Hermes, the Greek messenger God of the boundary is one such agent, and Eshu [13] a Trickster figure can be found

dwelling at the crossroads, a classical focal point of opportunity. These convergences do not always guarantee success, Trickster figures can unexpectedly sabotage as well as seize opportunity. This resonates with our observations of the initial fractious argument between the contractor and architect, which could have sabotaged working relationships. Following a relaxation of the official regulations the different parties met on site and quickly found an acceptable solution from which they could proceed. It is worth noting that the official documentation that was originally insufficient and part of the problem never changed. The 'relaxation' acknowledges the disparity that exists between general laws and reality, however the details of that relaxation were much more clandestine. They were discussed in less official face-to-face meetings rather than officially documented. We see a similar negotiation of official and unofficial during the structural example. Again an approved official document was insufficient and mobile phone and face-to-face communication proved to be effective at ameliorating the apparent brittleness of official modes of communication.

This observational evidence suggests formal communications—like architectural drawings and regulations—operate within Shannon and Weaver's framework; there is a level of information and detail beyond which an entire communicated message becomes corrupted. However, informal communication—which includes both face-to-face and mobile phone communication—advanced the examples and proved more successful for handling the negotiation of the nuanced and complex details that contributed to the overload and corruption of official communication. This challenges other propositions [14] [15] that attempt to contain all construction communication and information in formalized structures. It adds currency to the notion that the noise and furor surrounding design and construction contributes to a communicative gap that cannot be filled by formal communication.

Negotiation: Consolidating value frameworks

According to Durkheim conceptions of the sacred and the profane have strong associations with religion [16], although they are often incorrectly aligned with good and evil. The word 'sacred' comes from the Latin to *restrict, enclose or protect*. Profane comes from the Latin meaning *before the temple*. This implies that the sacred is aligned with notions of protection. The profane is then distinguished from this as something excluded from the protection bestowed on the sacred; it is benign and ordinary.

Re-examining the fire escape window through this lens we suggest the different disciplines invested in the construction project considered different aspects of the fire escape sacred. The local authorities considered the regulations as sacred; the architect considered the drawings as sacred; the contractor considered the site sacred. When the drawing of the fire escape window—part of which is illustrated in **Fig. 3**—was passed to the contractor it quickly became apparent that the window could not be installed as drawn. The drawing lost much—if not all—of its sacred value in the context of the construction site. The contractor proceeded and installed the window as illustrated in **Fig. 5** as they would in any other similar circumstance. It was installed further up the roof to facilitate better views from the room. It can be noted from **Fig. 3**, **Fig. 4** and **Fig. 5** that the window could have been installed much closer to the location as prescribed by the regulations and the drawing.

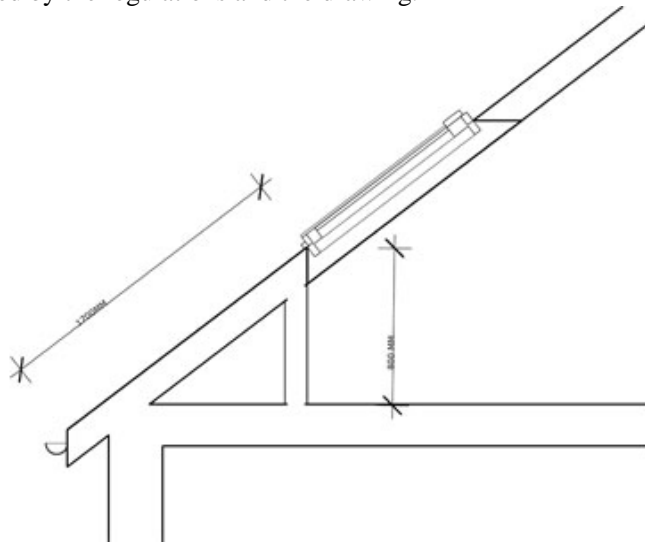

Fig. 3 Fire escape window drawing

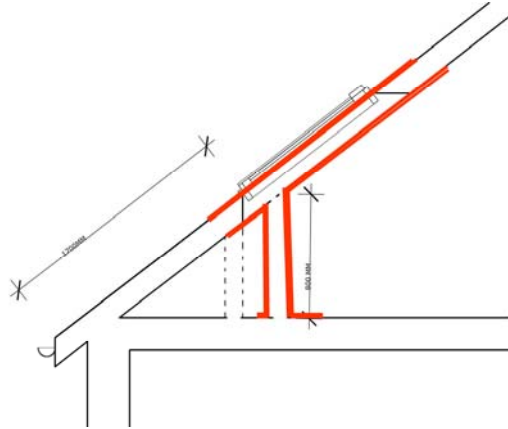

Fig. 4 Actual roof structure preventing window installation

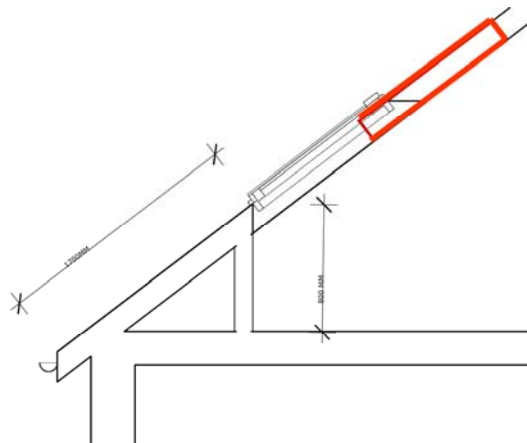

Fig. 5 Position of window as installed by contractor

Let us turning our attention to the construction of the staircase. Although it also involved highly prescribed documentation and regulations, it did not result in the same fractious and tense exchanges. There were two distinguishing factors in this example as compared to the previous. Firstly, the contractor lacked the knowledge or ability to make any independent progress. As a consequence the situation was not advanced at all, thus making any infringements on participants sacred values unlikely. Secondly, as a direct consequence of mobile phone conversations not advancing the situation the matter quickly advanced to a face-to-face meeting. In this meeting explicit instruction would have to be

given on all aspects of the staircase and the physical location marked with key measurements, and distances (**Fig. 2**).

None of the three test cases were advanced through formal channels alone. In fact reflection on the fractious fire escape argument suggests that invoking formal documentation actually caused the situation to deteriorate further. This is perhaps not unexpected, we discussed in the previous section that after resolution the official documentation still had not changed. Invoking the sacred and unchangeable could not advance the situation. The superiority of authority and the official is related to its ability to remain distant from change, and according to Fish [17], authority is undermined the more it changes or is challenged. It was here we found unofficial communication such as face-to-face meetings more successful, and where we suggest mobile phones have currency. The details that were negotiated in these instances were profane, benign, ordinary; not sacred and thus could be tuned, tweaked and manipulated by the participants to advance the staircase and fire escape situations. Unofficial communication sponsored by face-to-face and mobile phone communication enabled a nuanced tuning of detail. Although that detail may have been present in official documentation, the unchanging politics of formal documentation did not invite the necessary negotiation or manipulation.

Digital Fieldnotes

In a follow-up project we aim to further suppositions on digitally sponsored collaboration. Currently in the process of testing, the digital fieldnotes iPhone/iPad application was informed by two key findings from the previous examples. Firstly—in line with Shannon and Weaver's suppositions—observations during the three test cases would suggest that the formal conveyance of too much information and detail could corrupt the entire communiqué. Details and nuanced information seemed more successfully communicated informally and communicated within the site context. Suggesting there are benefits to discussion within close proximity to both the relevant context and the relevant participants. When information was sedimented within the context of a problem, pertinent details were quickly identified. It would appear from the observed test cases that individuals working within a group could then be more selective regarding the copious information that was available.

Secondly, the informal densification of information and detail we have just discussed serves as a catalyst for advancing the problematic situation. Our test cases point to informational mass enabling participants to identify

what we have framed as ‘profane’ or ordinary aspects of a problem that can be manipulated to consolidate the situation and participants. In line with Deleuze and Guattari’s suppositions regarding consolidation and iteration [18], the more recent iterations are most advanced and closer to an optimal solution.

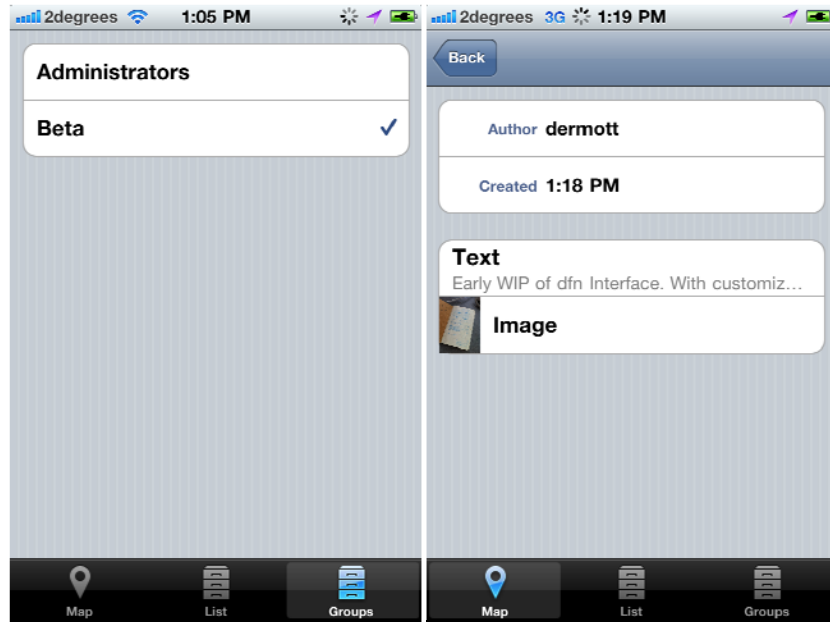

Fig. 6 Screenshots of the group selection screen and a typical 'fieldnote' containing both text and image

The digital fieldnotes iPhone application aims to create a framework based on these findings and exploits the contextual and temporal importance of informal information during the creative processes we have observed. The application—still in the beta testing phase—allows for the organization of informal ‘fieldnotes,’ which can be text and imagery tagged by temporal and locative metadata. It enables the creation of groups (**Fig. 6**), and participants within a group can access all the fieldnotes of that group (**Fig. 7**).



Fig. 7 A typical cluster of notes added at a meeting of several users

The digital fieldnotes application does not presume to replace face-to-face communication; rather it attempts to augment it by providing access to the furor surrounding inter-disciplinary group working that is normally lost in the noise and clamor of the construction site. Workshops with the application are underway but incomplete at the time of going to press, however the application provides a scaffold for the recording and retrieval of informal information and is attuned to the collaborative dynamics that we observed during our three test cases.

Summary

Studying a building project has provided observational evidence adding currency to the claim that unofficial noise and furor surrounding design and construction are not communicative inefficiencies to be expunged. This informal exchange of information by mobile phone, sketch and face-to-face meeting serves as a catalyst for team problem solving and creative discourse. It draws attention to the benign and ordinary detail that can be manipulated, flexed and tuned by different disciplines to advance

problematic situations and reveal opportunities. The authoritative nature of formal documentation and communication brings the inflexible, rigid and uncompromising rule of law to centre stage. While this is valuable to the macro-scale of project coordination and organization, at the micro-scale of problem solving these same formal channels reinforce the brittleness of collaboration and inter-disciplinary group working. The communicative intricacies of problem solving have been observed as being arcane and complex; and mobile phones—which are implicated within informal communication—have been a key constituent in finding innovative solutions and maintaining progress. Observed behavior supports Shannon and Weaver’s supposition regarding information overload and corruption, however being proximate to a particular location or problem could ameliorate this corruption. Within the observed situations the physical location was of particular importance, helping participants to identify pertinent information to advance the project. Mobile phones proved important for immediate transfer of information into and out of these multifaceted site conditions, the digital fieldnotes iPhone application represents some current work that aims to further advance our understanding of the influence of mobile computing on teamwork and creative practice.

Observational evidence supports the proposition that time and place play an import role in the mediation of information during collaboration. Mobile computing and locative media presents new opportunities for scrutinizing the communicative practices within multidisciplinary collaboration through these locative and temporal striations.

Acknowledgements

The authors would like to thank Nathan Ward from Braintrust who developed the Digital Fieldnotes application. We would also like to thank Judy Cockeram and Mark Gahegan who inspired some of the themes in this paper.

References

1. Coyne, R., *The Tuning of Place: Sociable spaces and pervasive digital media*. 2010, Cambridge, Massachusetts: The MIT Press.

2. Vitruvius. Encyclopædia Britannica 2011 09/01/11; Available from:
<http://www.britannica.com/EBchecked/topic/631310/Vitruvius>.
3. McEwen, I., *Vitruvius: writing the body of architecture*. 2003, London, England: The MIT Press.
4. Gann, D.M., A.J. Salter, and J.K. Whyte, *Design Quality Indicator as a tool for thinking*. Building Research and Information, 2003. **31**(5): p. 318-333.
5. Douglas, M., *Purity and danger: an analysis of concepts of pollution and taboo*. Routledge classics. 1978, London: Routledge.
6. Shannon, C.E. and W. Weaver, *The Mathematical Theory of Communication*. [A reissue.], The Mathematical Theory of Communication. ed. [Illini Books. no. 1B-13.]. 1963, Urbana: The University of Illinois Press.
7. Reddy, M.J., *The Conduit Metaphor: a case for frame conflict in our language about language*, in *Metaphor and thought*, A. Ortony, Editor. 1979, Cambridge University Press: Cambridge. p. 284—324.
8. Burry, M. *Digitally Sponsored Convergence of Design Education, Research and Practice*. in *CAAD Futures: learning from the past*. 2005. Vienna: Springer.
9. Lawson, B., *How designers think: the design process demystified*. 4th ed. 2006, Amsterdam; Oxford: Elsevier Architectural Press.
10. Kathryn Davies, *IT Barometer New Zealand - A survey of computer use and attitudes in the New Zealand construction industry*, in *CIB W78 - 27th International Conference on Applications of IT in the AEC Industry*. 2010: Cairo.
11. Sennett, R., *The Craftsman*. 2008, New Haven: Yale University Press.
12. McMeel, D., *The Artistry of Construction*, in *Architecture*. 2009, Edinburgh University: Edinburgh.
13. Hyde, L., *Trickster makes this world: mischief, myth, and art*. 1998, New York: Farrar, Straus and Giroux.
14. Kagioglou, M., et al., *Rethinking construction: the Generic Design and Construction Process Protocol*. Engineering, Construction and Architectural Management, 2000. **7**(2): p. 141-153.
15. Cushman, M. and T. Cornford, *Infrastructures for construction collaboration: The Cross Organizational Learning Approach*. International Journal of IT in Architecture, 2003. **1**(1).
16. Durkheim, E., *The Elementary Forms of the Religious Life*. 1954, London: George Allen & Unwin Ltd.

17. Fish, S., *Doing what comes naturally: change, rhetoric, and the practice of*. Post-contemporary interventions. 1989, Durham, NC: Duke University Press.
18. Deleuze, G. and F. Guattari, *A Thousand Plateaus*. 2004, London: Continuum.