

# COSEE: COMPONENT STATE NETWORK CENTRIC MODEL FOR VERIFYING TEMPORAL AND SPATIAL CONSISTENCY IN PROJECT SCHEDULES

Yuanbin Song and David K.H. Chua  
*Department of Civil Engineering, National University of Singapore, Singapore*  
[engp0361@nus.edu.sg](mailto:engp0361@nus.edu.sg) ; [cvedavid@nus.edu.sg](mailto:cvedavid@nus.edu.sg)

## SUMMARY

Constructability analysis is critical for the success of an AEC project, but its effective implementation is difficult due to the inherent complexity and multi-trades interaction over a frequently long development period. A consistently integrated project model can provide a collaboration platform among project designers, constructors, suppliers and owners/stakeholders to jointly improve the project construction. This paper looks at the integration of the key aspects, namely product, process, resource, and function, to facilitate the collaboration in constructability analysis. Specifically, it presents a COmponent State nEtwork cEntric (COSEE) Model to integrate these 4 important project aspects. Moreover, the relationships among product, construction work package, intermediate function system, and space resource model are examined. Based on the centric component state network and the relationship among the 4 aspect models, the spatial and temporal consistency in the project schedule can be verified.

**Keywords:** scheduling, component state network, project integration model, temporal constraint, spatial constraint, and Constructability analysis.

## INTRODUCTION

### Constructability analysis by collaboration of multi-trades

AEC projects are inherently complex products that are often collaboratively realized by many participants in various trades such as stakeholders, designers, constructors, subcontractors, and suppliers. Besides traditional precedence, construction process and related resource logistic activities frequently impose additional requirements and constraints, especially temporal and spatial ones, for the project design and programming. Many factors should be considered during design, like the intermediate function required by the constructors, temporal facility selection and design, and construction resource logistic management. It is often required for the participants in various trades to collaboratively consider these requirements and constraints as early as possible in project product design and construction programming. Thus, the importance of constructability analysis in the AEC industry can never be overemphasized.

The concept of constructability analysis stresses the incorporation of construction knowledge and experience into the project development lifecycle (CII 1986), and emphasizes the collaboration among different trades in sequential project phases (CII 1987). The constructability review process and the project development process are mainly bridged by information exchange (Anderson et al. 2000). Such studies concur that the timely identification of constructability requirements and quick feedback of conflicts are the main information content for constructability analysis.

### Integrated project information model for Constructability analysis

An integrated project information model is the cornerstone for constructability analysis. Function, product, process, and resource are four important aspects of a project in constructability analysis. Various models have been developed to integrate these four aspects of a real AEC project in order to unify representation, to facilitate analysis and to smoothen communication among the AEC participants distributed in different trades.

Many models have studied the integration of the product and process aspects of an AEC project. STEP and IFC models have been developed to provide a unified project information representation framework. Luiten et al. (1998) states that a construction activity starts with certain state and end with the updated construction state of a component. McKinney and Fischer (1998) used an integrated 4D product and process model to incorporate such product component relationships, like 'support' relationship, as indirect constraints to further review the constructability of the construction schedule and then optimize the design by schedule constructability review. Chua and Song (2001) developed a Component state Criteria (CSC) model to improve the constructability of a merged construction process schedule by evaluating component state criteria and intersection spatial constraints. Akinci et al. (2002) detected temporal space conflicts in a construction schedule by pair-wise analysis of collision between the space occupations of each two activities. However, the function aspect of an AEC project has been inadequately addressed, especially intermediate functions provided by the in-progress project, have seldom been studied.

### Common features of the previous integration models

There exist some common features among the previous integration models. These common features are:

- (1) process aspect centric:  
The CPM-based process aspect model is often the integration center that links with other aspect models, and project scheduling is often based on an activity network,
- (2) verifying schedule consistency:  
By relating a process aspect model with other aspect models, the relationships between entities in other models can be employed as indirect constraints for checking the consistency of the construction process schedule. The 3 typical types of indirect constraints include:
  - a. Component precedent relationship such as 'support' (McKinney and Fischer 1998);
  - b. Space disjunctive relationship such as 'non-collision' (Akinci et al 2002; Chua and Song 2001); and
  - c. Component state conditions such as 'component state chain', 'start prerequisite criteria', and 'end update criteria' (Luiten 1998; Chua and Song 2001,2002), and
- (3) The product components and process activities are directly linked with many-to-many relationship as illustrated in Figure 1.

Figure 1 shows the association relationship between product component and process activity using a class diagram. The important attributes of the activity class are the start and end events. The term 'state' is used to represent the status or configuration of a component in its construction lifecycle. In most of the integrated project models, states are frequently derived from the construction progress during simulation where their durations are often the interval between two activity events. We call such states 'process-oriented states' in this paper.

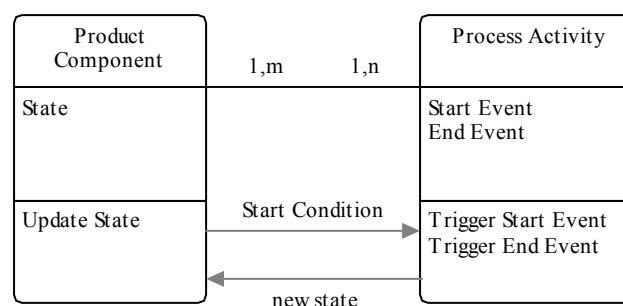
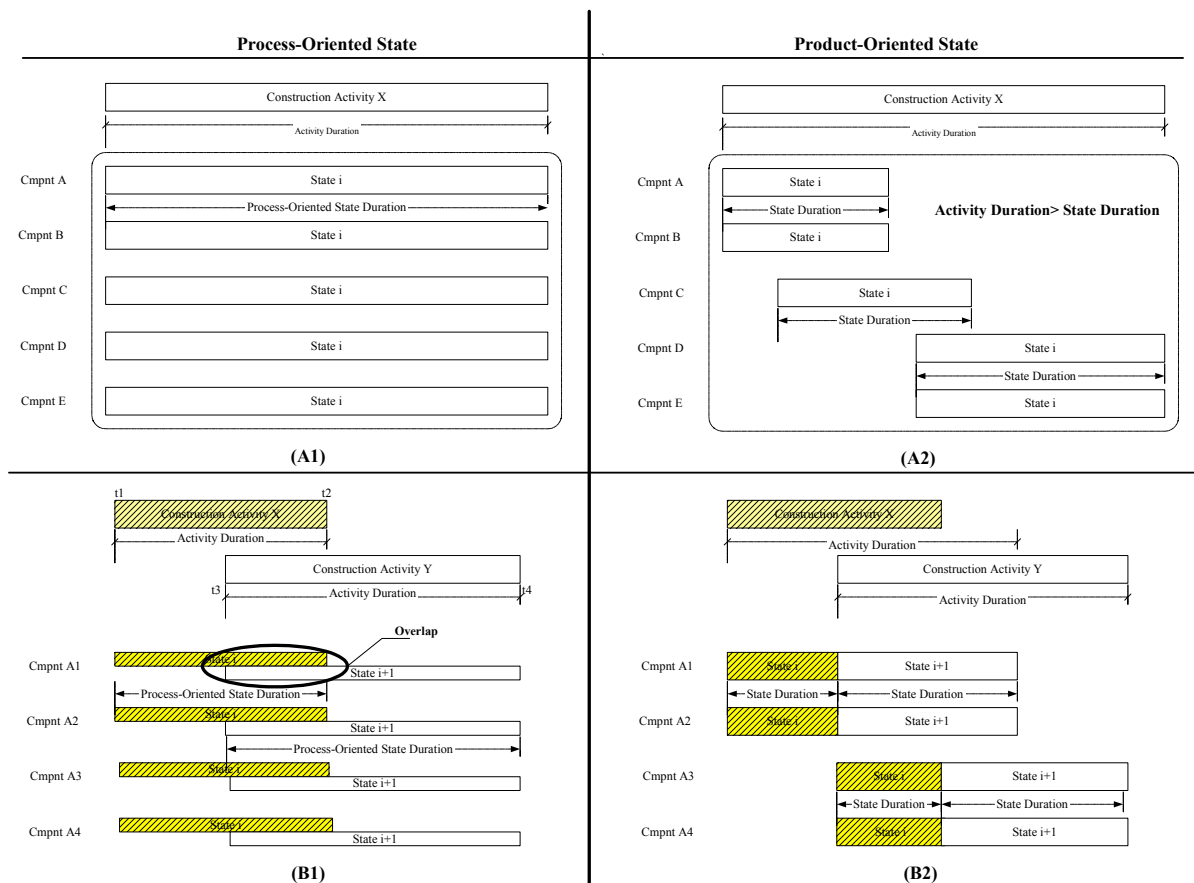

**Figure 1** Relationship between components and activities

### Implicit issues about process-oriented states

However, such activity-centric representation leads to 3 implicit issues about a process-oriented state. The first is the state duration. As derived from the construction activity during process simulation, the component state duration is often equal to the activity duration (Figure 2(A1)). However, the component state duration may be less than the activity duration in the CPM schedule. Figure 2(A2) shows that Activity X of a typical CPM is performed on the components A, B, C, D, and E. Figure 2(A2)

also shows that the durations of the 'state i's of these five components are all less than the duration of Activity X. However, Figure 2(A2) illustrates that the states involved in the same activity can overlap depending on crew and equipment assignments. For example, the 'State i' of Component B overlaps with that of Component C. The second difficulty results from the ambiguity in the first. Figures 2(B1) and (B2) depict two activities X and Y that overlap. Activity X transits the 'state i's of the components in a work package, while Activity Y transits the 'State i+1'. From the process-oriented state perspective, the start point of 'State i+1' will be initiated by both the finish of Activity X at  $t_2$  and the start of Activity Y at  $t_3$ , and this presents a conflict of the states in the time interval ( $t_3 - t_2$ ). Actually, the components A3 and A4 are sequenced after the components A1 and A2 for site reasons. The product-oriented state perspective correctly depicts the sequence pattern of the component states as shown in Figures 2(B2). The durations of the activities X and Y are the combination of the durations of the associated 'State i's and 'State i+1's respectively. The third is that the component states derived from the process simulation are disjointed without state relationship explicitly linking them into a network.



**Figure 2** Implicit Issues about process-oriented states

Another issue less discussed in most previous integrated project models is how to integrate the project system functions into these models. The value engineering studies presented a diagramming method, namely Functional Analysis System Technique (FAST) (Bytheway 1964). This tool can be used to hierarchically develop the high level requirement into detailed functions and also can allocate the functions to the components (Kelly, J., and Male, S. 1993). This modeling method can be applied for the final function analysis of a finished AEC project, but cannot be easily applied for intermediate function analysis for an in-progress AEC project because the availability of the intermediate functions often depend on the in-progress states of the product components.

In Component State Criteria model, the component state and its duration are directly defined by the estimated component configuration transition during its construction period (Chua and Song 2001). Such state is call 'product-oriented' state to distinguish it from 'process-oriented' state concept as defined in most of the previous models. The component states relate with each other to form a network, which is the core of the Product Oriented Scheduling Technique (POST) model (Song and

Chua 2002a). The component state criteria can be employed as a knowledge representation method to represent component state chain knowledge, component interaction knowledge, and intermediate function knowledge (Chua and Song 2002b).

### COSEE model for integrating four project aspect models

The component state network can be used to not only collaborate on the temporal constraints among different aspect models, but also the spatial constraints among them. The COmponent State nEtwork cEntric (COSEE) model presented herein that integrates these four important aspect models (product, process, intermediate function, and space resource) of a project employs the component state network as a kernel for verifying both temporal and spatial consistency in the project schedule.

### STRUCTURE OF THE COSEE MODEL

Construction programming must satisfy the temporal constraints of 4 project aspects, namely product, process, intermediate function, and space. It is required to integrated these 4 aspect for evaluating the temporal and spatial consistency of a schedule. In high level, there are mainly two methods to integrate these aspect models together. One is to link these models in a pair-wise fashion, and the other is to link them together with a kernel model. As discussed in the introduction section, most of the previous studies use the first method to link product and process models, and employ the second method to link product and space aspects with the process-centric aspect model. However, COSEE model applies the hybrid method to combine the two methods with a component state network as its center as shown in Figure 3.

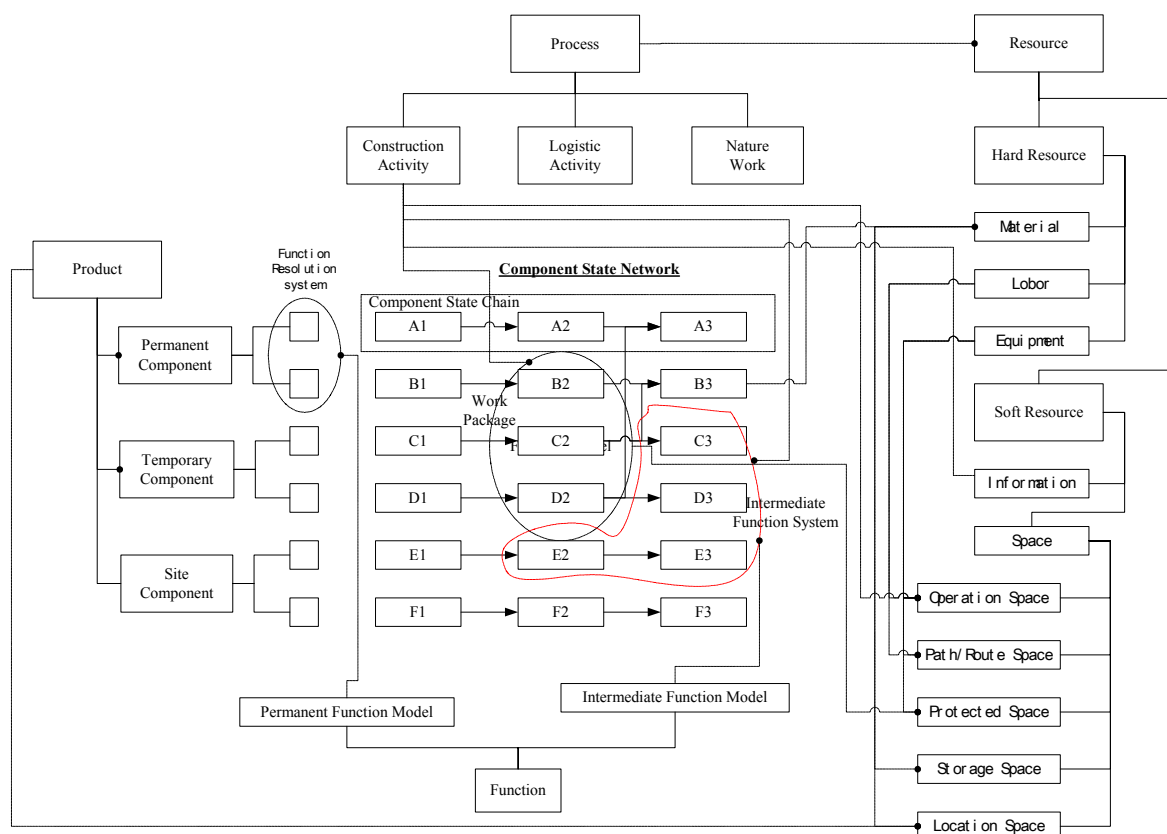

Figure 3 Structure of COSEE model

Compared to the direct relationships between the product components and the process activities as shown in Figure 1, the relationship between product component and process activity is indirect in

COSEE, referred through the same kernel (component state network). The construction lifecycle of a component can be mapped as a state chain in the component state network, while a construction activity is mapped as a work package (Song and Chua 2002). Such a reference provides a more accurate temporal description for both product components and construction activities and explicitly represents the link between the product model and process model.

The function hierarchical tree is firstly classified into two main branches. One is the permanent function model that describes the final project function hierarchy, which comprises the functions required by the end users. The other is the intermediate (or temporary) function hierarchy whose functions serve the construction requirements for constructors. The function hierarchy shows the function composition from high-level comprehensive functions to low-level detailed function. An atomic function in the permanent function tree can refer to a set of components in their final states, whereas a temporary function in the intermediate function tree refers to a set of components that can be in several suitable states.

Traditionally, construction resource is classified as labor, material, and equipment. Recently, the scope of resource is extended to involve such 'soft' resources as information and space. The COSEE model also categorizes construction resources from the viewpoint of their lifespan in the AEC product. Accordingly, construction resource can also be classified as permanent and temporary resources. Permanent resources such as most materials will retain either their original nature or their transformed nature after construction. These are often specified clearly in the product design. The COSEE model relates the component state with the material resources to describe their historical incorporation in the product system. On the other hand, the temporary facilities are often not detailed in the design documents, and the temporary resources such as labor and equipment are not part of the permanent product system. However, these temporary facilities and resources play important roles in construction scheduling and frequently affect construction space programming, thus they need to be represented in the COSEE.

Besides the temporal attributes, the spatial attribute is another important characteristic for the four project aspects. From the extended resource viewpoint, space is a kind of competitive resource during construction. The COSEE model references product components, process activities, and traditional resources to a 3D space model for spatial constructability analysis. Figure 3 illustrates that space resource can be mainly categorized as operation space, storage space, path/route space and protected space. The location space is a kind of product-oriented space resource, whereas the operation space is a kind of process-oriented space resource. A construction activity may use several space entities. As construction proceeds, the shape of the component can change. Storage spaces can be employed to depict where the materials are located on site, and path/route spaces represent the access of heavy equipment. By representing these space entities in a shared 3D model, such spatial relationships as topological relationships and location association relationships can be represented. In this way, spatial consistency can be checked, so that spatial constraints can be evaluated in construction programming.

## **TEMPORAL AND SPATIAL CONSISTENCY IN COSEE**

### **Temporal and Spatial Constraints in COSEE**

The temporal relationships between states are categorized into 3 types, namely, precedent relationship, coupling relationship, and disjunctive relationship. The precedent relationships are the four traditional relationships in CPM, i.e. start-to-start (SS), start-to-finish (SF), finish-to-start (FS), and finish-to-finish (FF). The coupling relationships can be categorized into strong and weak coupling types. The strong coupling (or double coupling) relationship defines that both the start points and the finish points of the two states should occur concurrently. The weak coupling relationships are either start coupled (where only the start points occurs concurrently) or finish coupled (where only the finish points occur concurrently) (Song and Chua 2002). The disjoint relationship describes that the two states cannot overlap. The precedent relationships are the basic types, and the coupling relationships and disjoint relationship can be translated or simplified as precedent relationships as shown in Table 1. There is a start coupling relationship between state 'S5' and state 'S6', and this coupling relationship can be translated into two precedence relationships as the dot line arrows shown in Table 1. Because state 'S5' and state 'S6' need to start simultaneously, the precedence relationships restricting the start

of 'S5' will also restrict 'S6', and vice versa. Similarly, an end coupling relationship between two states can also be translated into 2 precedence relationships. The disjunctive relationship between two states 'S1' and 'S2' means that 'S1' either precedes or succeeds 'S2', but these two states cannot occur concurrently. These temporal relationship types can enrich the semantic representation of temporal association between two component states.

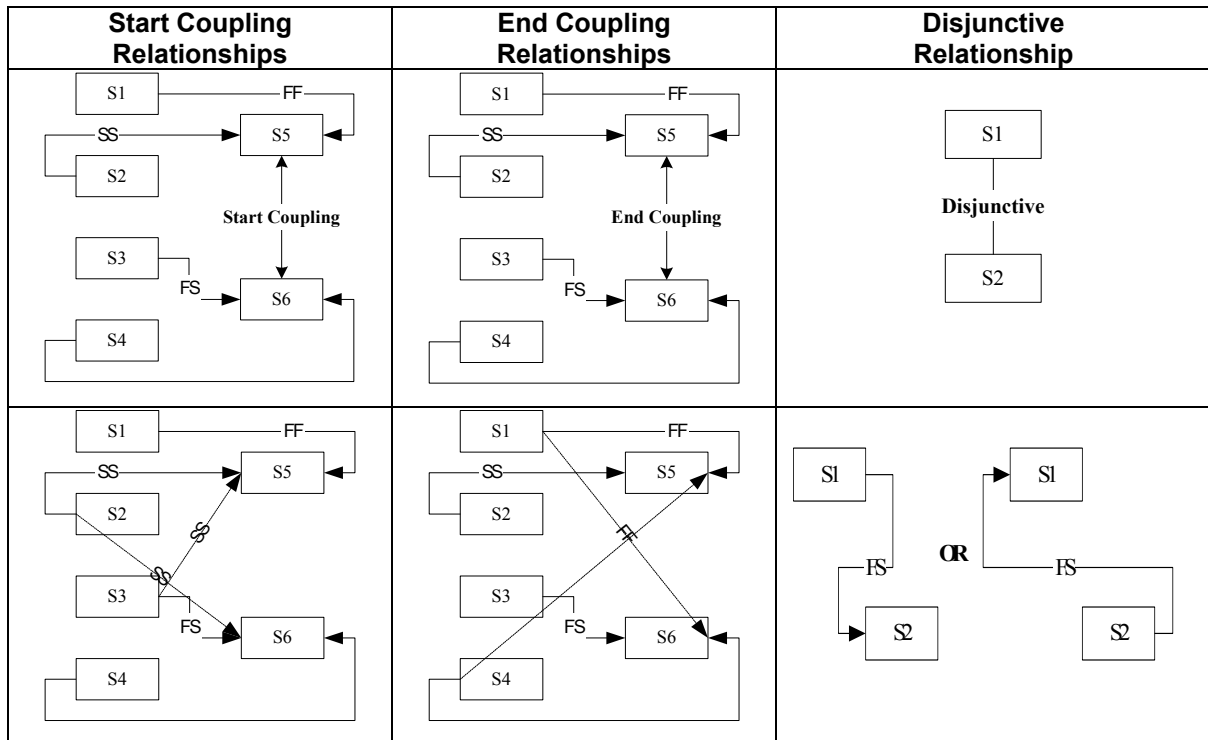

**Table 1** Translation of complex temporal relationships into precedent relationships

The spatial relationships can be categorized into 2 main categories, namely topological relationships and location association relationships. The location association relationship defines the geometric reference between two shape entities. Eight types of binary topological relationships between two 2D regions have been defined based on the point set topological relationship studies (Egenhofer and Franzosa, 1990, 1991). Similar to the definition of the binary topological relationships between 2D regions, the binary topological relationships between two 3D solids can also be defined based on the 9-intersection matrix. In the present study, the 3D topological relationships are classified into 8 types, namely disjoint, meet, intersect, equal, enclosed-by, enclose, contained-by, and contain. Figure 4 illustrates the 8 binary topological relationships using two solid spheres. This 3D topological relationship set is mutually exclusive and closed, meaning that the topological relationship between two solid shape entities must be one and only one of the 8 relationships.

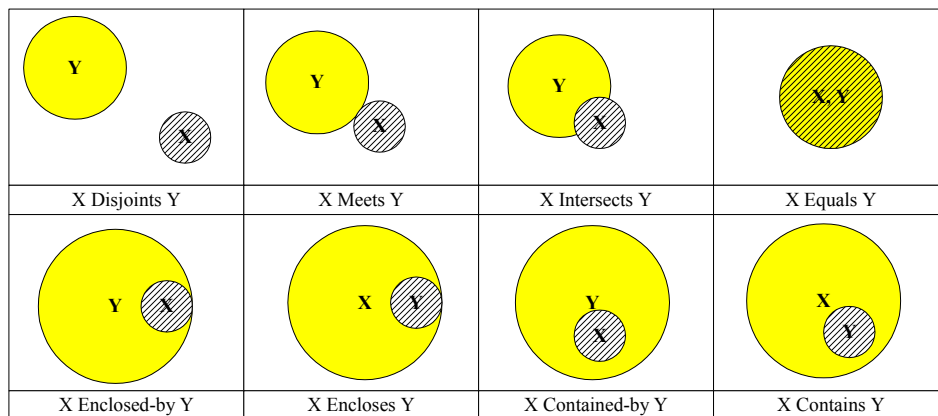
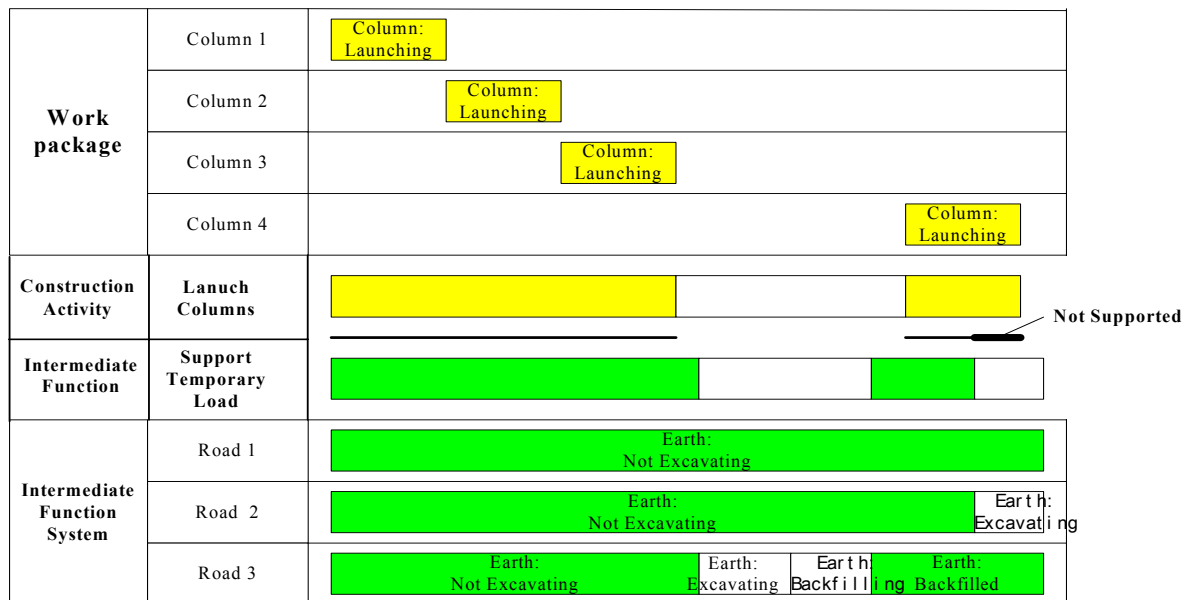

**Figure 4** Eight binary topological relationships between two solid shape entities

## Collaborative Consistency Verification in COSEE

In COSEE the entity relationships within the process, function, and resource aspect models and the relationships between them impose the additional and indirect constraints for construction programming. Such relationships should be included in the component state network to make it temporally and spatially consistent. The present paper focuses on evaluating the availability required by construction activities.

Only if a activity to construct the work package is supported by the available utilities of the intermediate functions can the activity be suitably programmed. The duration of an activity can be derived from merging the individual durations of the states in a work package, while the available duration of an intermediate function is determined by the concurrent existence of the suitable states of the product components, which are in a intermediate function system. For example, the 'launching precast columns' construction activity requires the intermediate function 'supporting temporary load' provided by the intermediate function system, which includes Roads 1, 2, and 3. Figure 5 illustrates that the work package for the activity 'launching precast columns' includes the product components 'Column 1', 'Column 2', 'Column 3', 'Column 4'. Figure 5 shows that the activity progress is not continuous in this example. The suitable states of a site road for providing the intermediate function 'supporting temporary load' can be states 'not excavating', 'backfilled', and 'paving', and 'paved'. There are two periods when the intermediate function is not available due to the excavation of the roads. The second unavailable period results in a scheduling problem. The scheduled 'launching Column 4' is not permissible due to the unavailability of the intermediate function 'supporting temporary load'.



**Figure 5 Matching Work Package and Intermediate Function**

In COSEE, the spatial entities of the component states, process operation, resource allocation (storage), and transportation path (route) are integrated in a unified 3D model for verifying spatial consistency. The spatial consistency of construction programming is also time-dependent. In other words, the verification of spatial planning consistency is a spatio-temporal inference procedure. The start of construction process will occupy the operation space while its end will release the once occupied space. Some spatial relationships are only valid during certain periods. For example, the adjacent relationship between the crane route space and the beneath road is valid only before road excavation and after road backfill. Chua and Song (2001) have executed a spatio-temporal consistency case study to resolve the conflict between pipe occupation spaces and wall plastering spaces.

## CONCLUSIONS

This paper discusses the implicit issues in the previous integrated product and process models, and then suggests the COSEE model to integrate the 4 important project aspects, namely intermediate function utility, product, process and resource for constructability analysis. These 4 aspect models are integrated around the kernel component state network. The relationships among product, construction work package, intermediate function system, and space resource model are explained. Based on the centric component state network and the relationship among the 4 aspect models, the spatial and temporal consistency in COSEE can be verified for constructability feedback. How to practically schedule COSEE state network will be one of the future research works.

## REFERENCES

- Anderson, S.D., Fischer, D.J., and Rahman, S.P. (2000) *Integrating Constructability into Project development: a Process Approach*, Journal of Construction Engineering and Management., ASCE, 126(2), 81-87.
- Akinci B. and et. al. (2002) *Formalization and Automation of Time-Space Conflict Analysis*, Journal of Computing in Civil Engineering., ASCE, 16(2), 124-134.
- Chua, D.K.H. and Song, Y. (2001) *Component State Model and its Application in Constructability Analysis of Construction Schedule*, Proceedings of the 8th International Conference on Civil Structural Engineering Computing, Eisenstadt, Austria 19-21, Sept. 2001.
- Chua, D.K.H. and Song, Y. (2002) *Component State Criteria Representation to Incorporate Construction Program Knowledge for Constructability Analysis*, 2003 Construction Research Congress, March. 19-21, 2003, Hawaii (in print).
- Construction Industry Institute (1986) *Constructability: A Primer*, Publication of 3-1, The University of Texas at Austin.
- Construction Industry Institute (1987) *Constructability Concepts File* Publication of 3-3, Bureau of Engineering and The University of Texas at Austin.
- Egenhofer, M., and Franzosa, R. (1990) *A Mathematical Framework for the Definition of Topological Relationships* The 4<sup>th</sup> International Symposium on Spatial Data handling, Zurich, Switzerland, 1990, 803-813.
- Egenhofer, M., and Franzosa, R. (1991) *Point-set Topological Spatial Relations*, International Journal of Geographical Information Systems, 5(2), 161-174.
- Kelly, J., and Male, S. (1993) *Value Management in Design and Construction: The Economic Management of Projects*, E&FN Spon, an imprint of Chapman & Hall, First Edition.
- Luiten, G.T., Tolman, F.P., and Fischer M.A. (1998) *Project-modeling in AEC to integrate design and construction*, Journal of Computers in Industry, 35, 13-29.
- McKinny, K., and Fischer, M. (1998) *Generating, Evaluating and Visualizing construction Schedules with CAD Tools*, Journal of Automation in Construction., ASCE, 7(6), 443-447.
- Song, Y. and Chua, D.K.H. (2002) *POST: Product Oriented Scheduling Technique for Constructability Analysis*, Proceedings of the International Workshop on Information Technology in Civil Engineering, Nov. 2-3, 2002, Washington, D.C., ASCE, 124-135.