

# Digital Logic Structures

CS 210

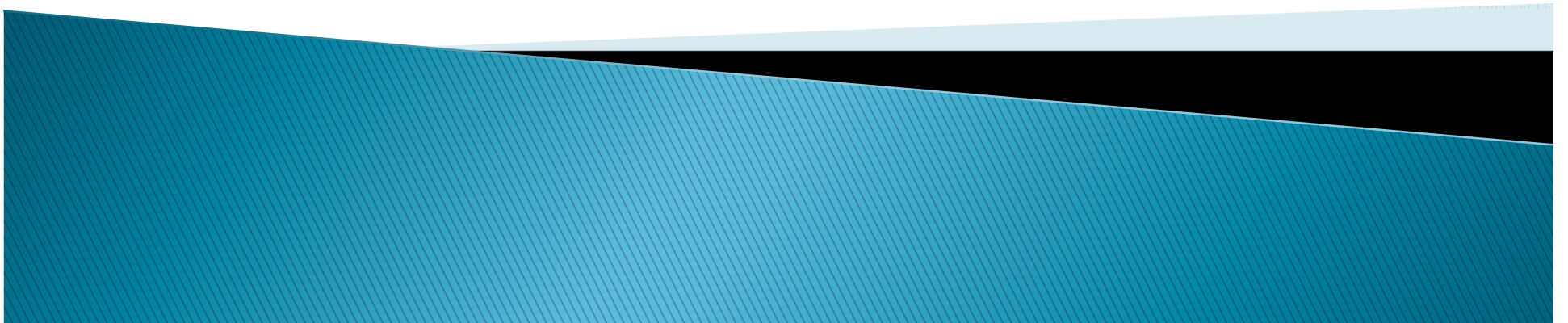

# Introductions

- ▶ How do we represent data in a computer?
  - Easy to recognize two conditions:
    - 1. Presence of a voltage – we'll call this state "1"
    - 2. Absence of a voltage – we'll call this state "0"



Computer use transistors as switches to manipulate bits

- Before transistors: tubes, electro-mechanical relays (pre 1950s)
- Mechanical adders (punch cards, gears) as far back as mid-1600s

Before describing transistors, we present an analogy...

- ▶ Transistor: Building Block of Computers

- Two types
  - N-type
  - P-type

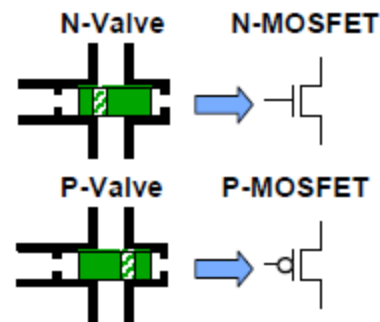

# Types of transistors

## ▶ N-type Transistor

- When Gate has positive voltage, short circuit between #1 and #2 (switch closed)
- When Gate has zero voltage, open circuit between #1 and #2 (switch open)

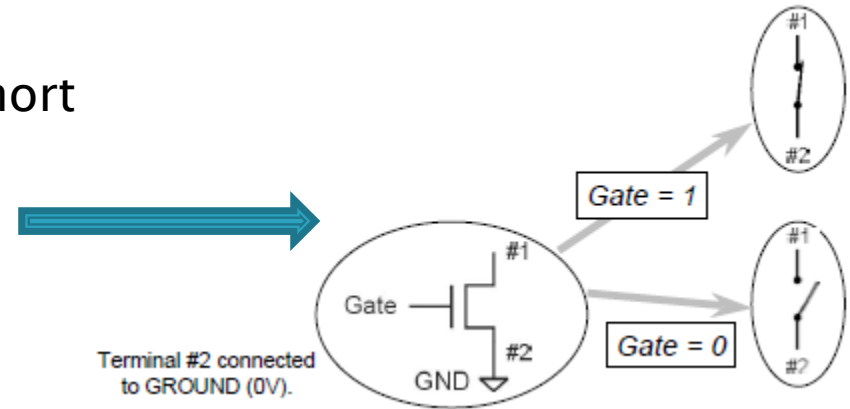

## ▶ P-type Transistor

- P-type is complementary to n-type
- When Gate has positive voltage, open circuit between #1 and #2 (switch open)
- When Gate has zero voltage, short circuit between #1 and #2 (switch closed)

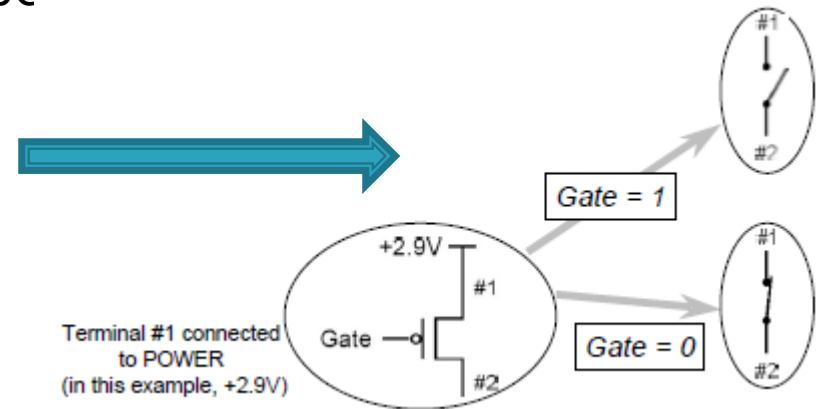

# Basic Gates

NOT/INV

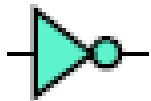

NAND

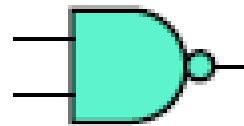

AND

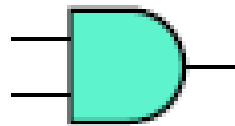

NOR

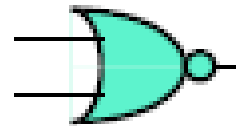

OR

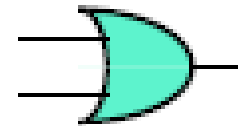

Inverter (NOT Gate)

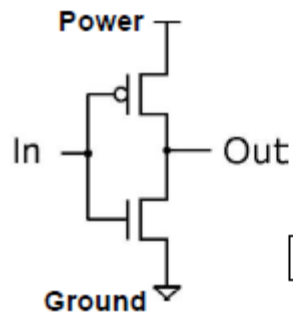

Truth table

In	Out
0	1
1	0

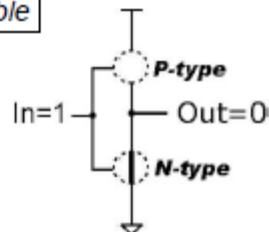
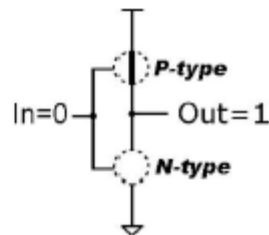

NAND Gate (NOT-AND)

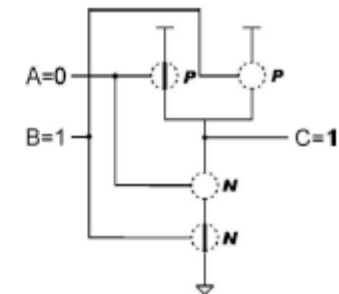
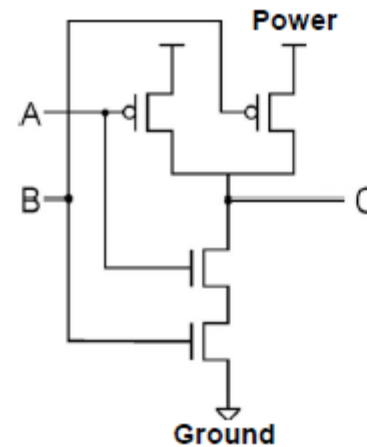

A	B	C
0	0	1
0	1	1
1	0	1
1	1	0

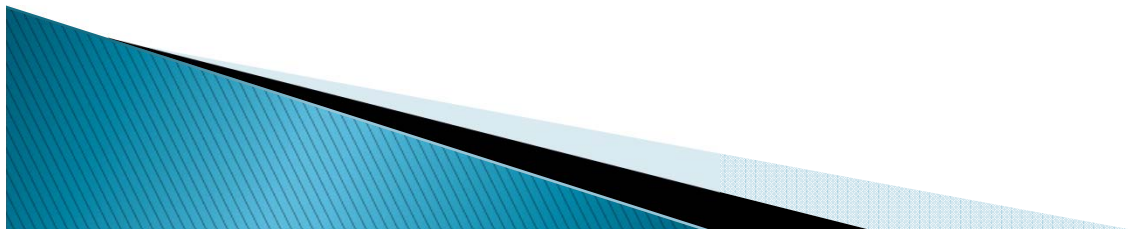

# Basic Gates

## AND Gate

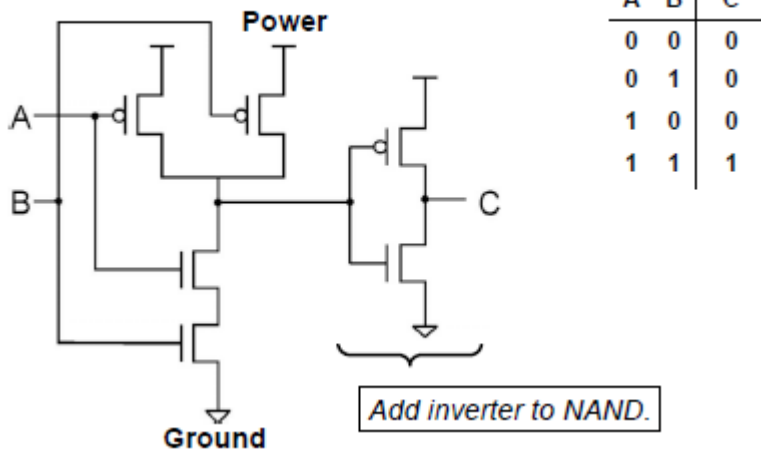

## NOR Gate (NOT-OR)

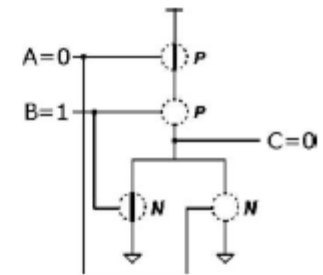
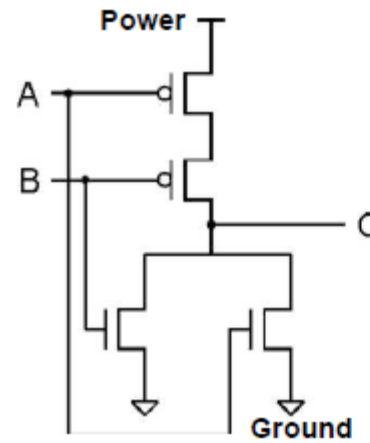

A	B	C
0	0	1
0	1	0
1	0	0
1	1	0

## OR Gate

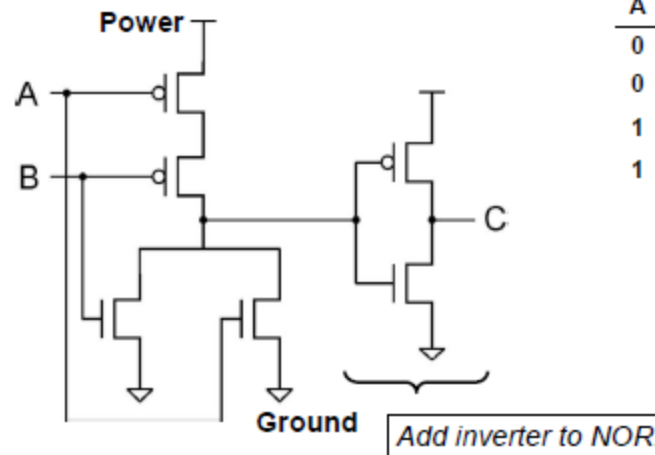

A	B	C
0	0	0
0	1	1
1	0	1
1	1	1

# Exercise

- ▶ 1. Warm-up:
  - Write out the truth tables for AND, OR having 2-bit inputs
  - and XOR using 3-bit input
  - Hint for XOR: use the property of associativity;  $A \oplus B \oplus C = A \oplus (B \oplus C)$

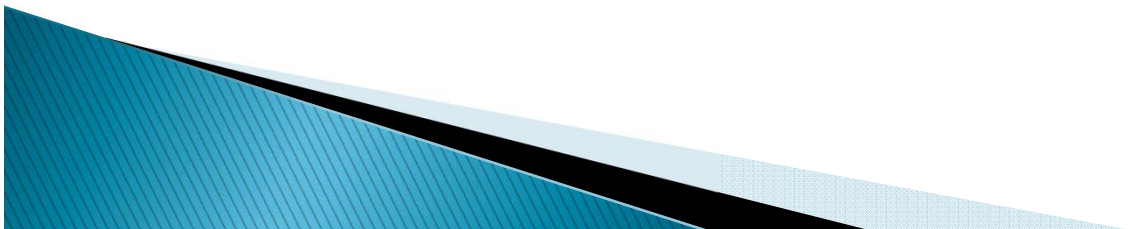

# Answer for XOR:

A	B	C	Z
0	0	0	0
0	0	1	1
0	1	0	1
0	1	1	0
1	0	0	1
1	0	1	0
1	1	0	0
1	1	1	1



# Exercise

- ▶ a) Replace the missing blue circles in the shown circuit with either a wire or no wire to give the output C a logical value of 1.
- ▶ b) Describe a set of inputs that give the output C a logical value of 0. I.e. write out the truth table.
- ▶ c) What type of gate does this circuit represent?

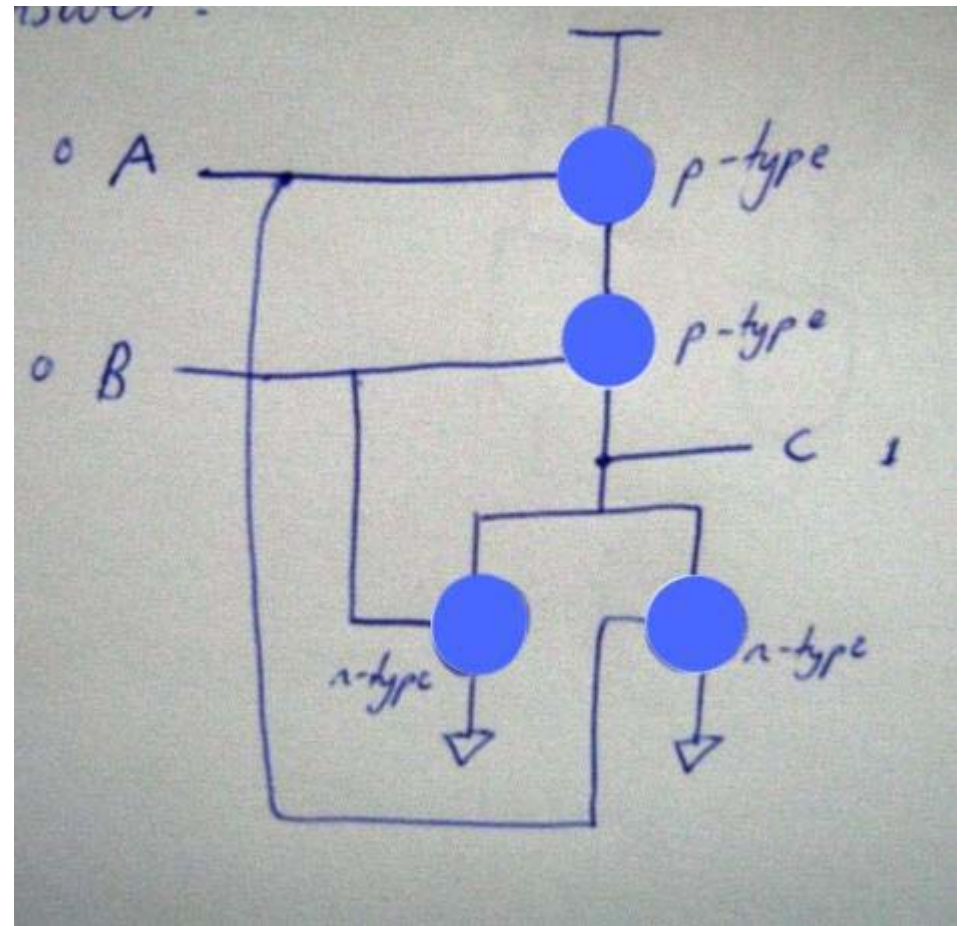

# Answer

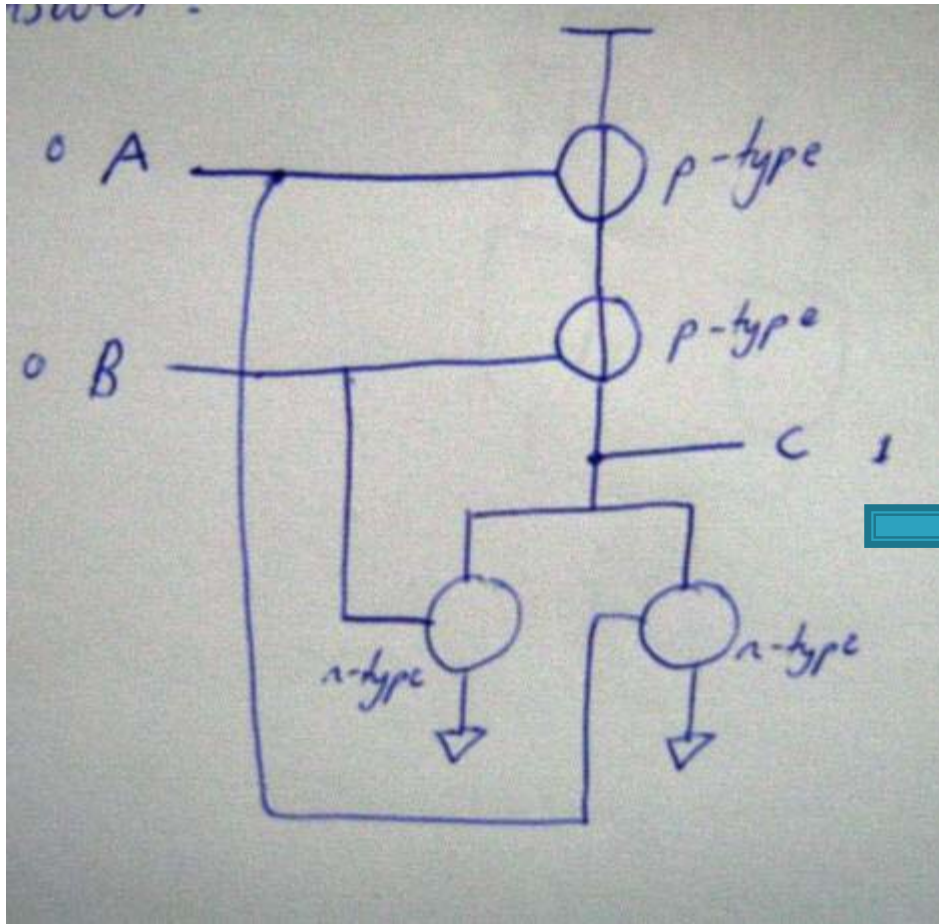

A	B	C
0	0	1
0	1	0
1	0	0
1	1	0

- ▶ Therefore it represents a NOR gate

# Exercise

- ▶ For the transistor-level circuit in the following Figure, fill in the truth table. What is Z in terms of A and B?

A	B	C	D	Z

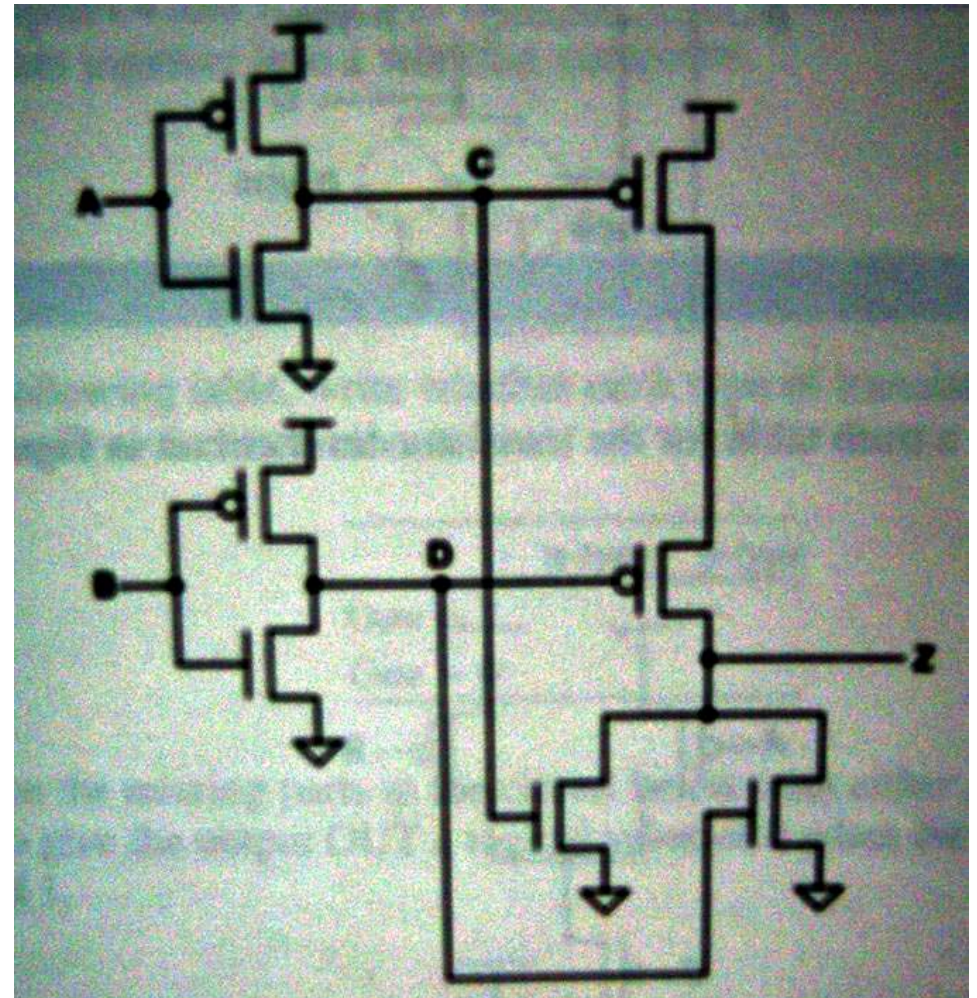

# Answer

- ▶ Truth table:

A	B	C	D	Z
0	0	1	1	0
0	1	1	0	0
1	0	0	1	0
1	1	0	0	1

- ▶ Therefore  $Z = A \text{ AND } B$



# Exercise

- ▶ What is the flaw in the following circuit? Analyse it by working through the truth table and seeing which inputs show up the flaw.

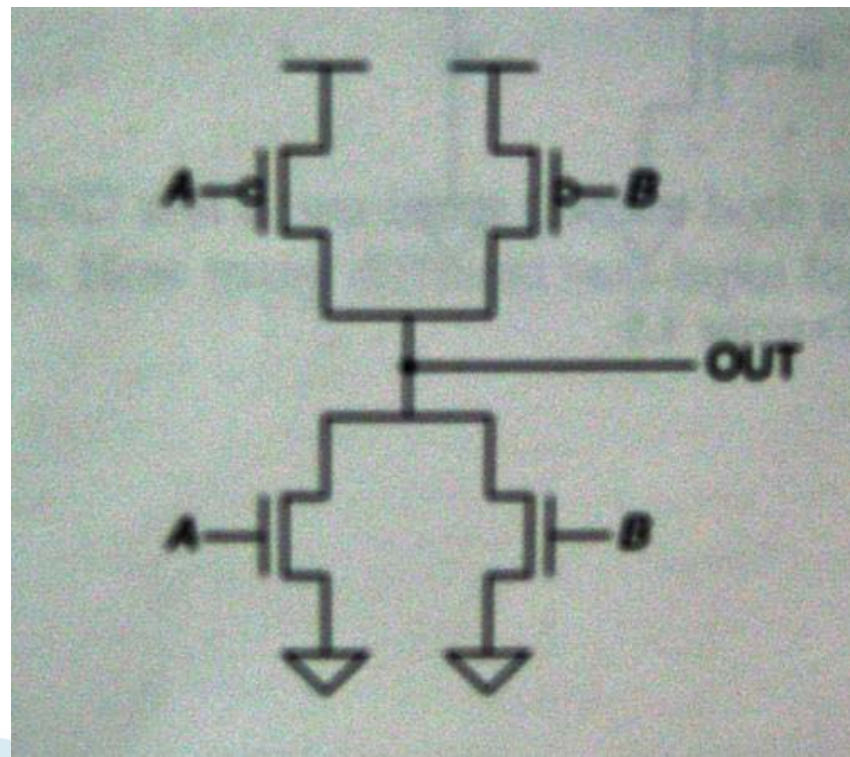

# Answer

- ▶ The circuit will short-circuit for certain inputs.

A	B	Output
0	0	1
0	1	1 (short circuit!)
1	0	1 (short circuit!)
1	1	0

- ▶ Why?

